

# Basic Heater System Schematic

MDI brand Contactor Wiring

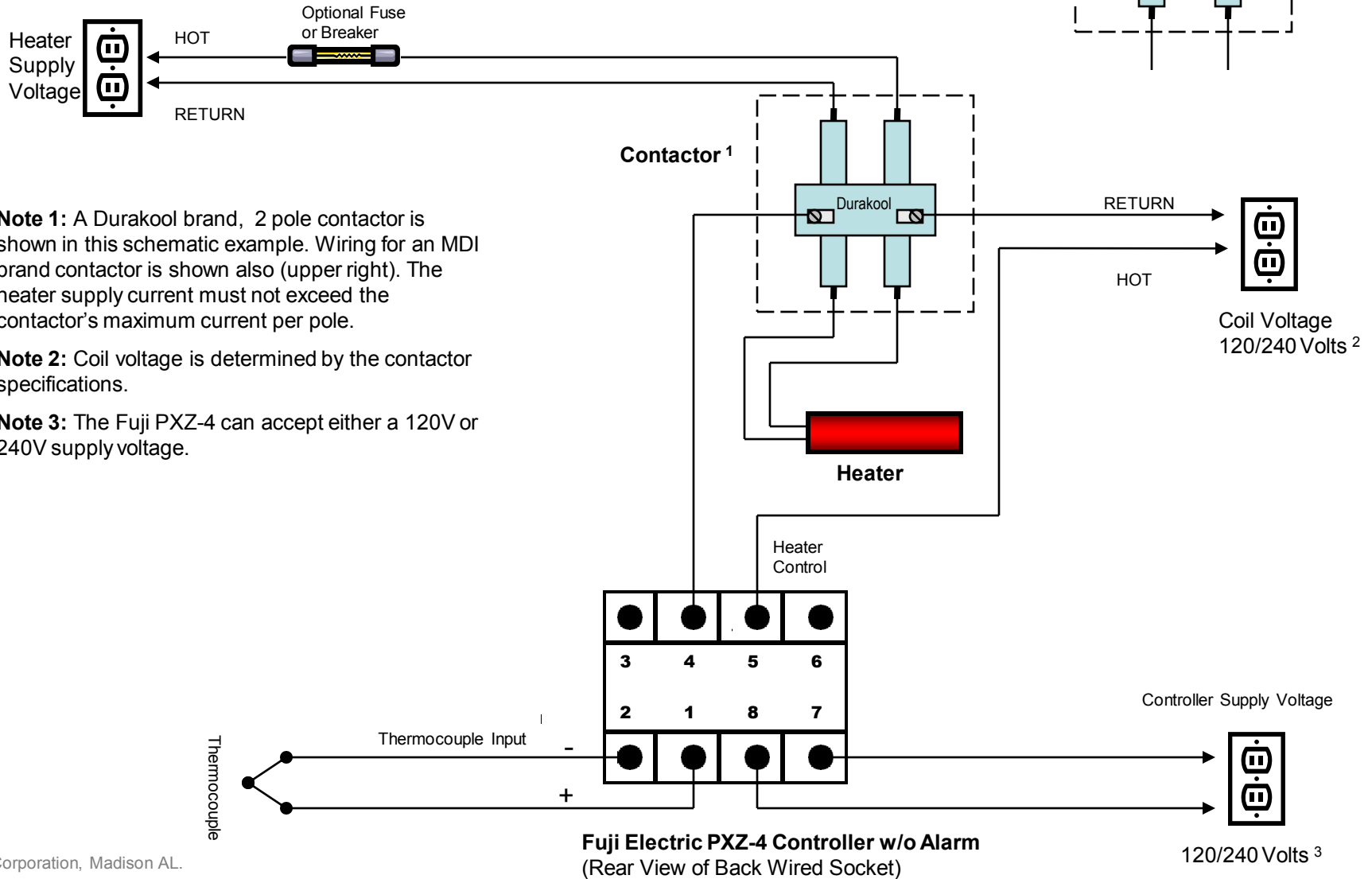
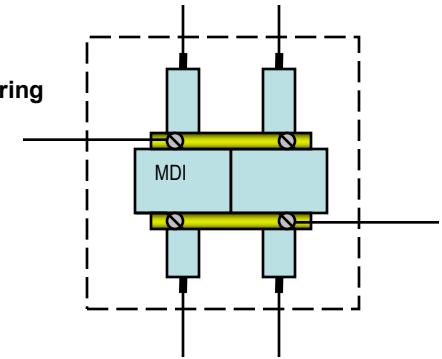

**Note 1:** A Durakool brand, 2 pole contactor is shown in this schematic example. Wiring for an MDI brand contactor is shown also (upper right). The heater supply current must not exceed the contactor's maximum current per pole.

**Note 2:** Coil voltage is determined by the contactor specifications.

**Note 3:** The Fuji PXZ-4 can accept either a 120V or 240V supply voltage.

Coil Voltage  
120/240 Volts<sup>2</sup>

Controller Supply Voltage

120/240 Volts<sup>3</sup>

Fuji Electric PXZ-4 Controller w/o Alarm  
(Rear View of Back Wired Socket)